



float<sup>®</sup>

Humanscale<sup>®</sup>

# Introducing Float

## The World's Most Revolutionary Height-Adjustable Table

Thanks to its innovative and proprietary design, the Float height-adjustable table solves the problems and limitations of current-generation sit/stand tables, gracefully adapting to a vast range of heights and weights with exceptional ease of use and safety features. Its ingenious counterbalance mechanism provides constant counter-weighting force that allows the table to move fluidly between sitting height and standing height, while accommodating the ergonomic needs of 99% of users.



## The Dangers of Sedentary Work

While most office workers sit for the majority of their workdays, research shows that all-day sitting is a serious health risk. But standing all day at work isn't healthy either, causing discomfort and swelling in the legs and feet. Therefore, the most effective way to maintain health and comfort in the workplace is to alternate periodically between sitting and standing postures.



## Features

- Unmatched performance and ease of use encourage desk-bound workers to regularly alternate between sitting and standing postures for long-term health
- Simple, single-handed weight adjustment instantly accommodates changes in tabletop weight
- Innovative safety features allows up or down adjustment only when the desktop and contents are properly counterbalanced
- With a clean, sophisticated aesthetic, Float complements any work environment while offering plenty of room under the work surface for legs, knees, and feet
- Built for a long, serviceable life and limited carbon footprint, the Float height-adjustable table is made using minimal parts and manufacturing processes and is comprised predominantly of recyclable steel

## Environmental Story

Humanscale supports a materials economy that is healthy and safe for people and the environment. That's why unlike most height-adjustable tables, Float uses premium grade powder coat wood tops that are made without formaldehyde. Certified as one of the world's first Living Products by the International Living Future Institute, when you purchase a Living Product-certified configuration of the Float table, you are making a positive contribution to the environment. Learn more at [Humanscale.com/LivingProductChallenge](https://www.humanscale.com/LivingProductChallenge).

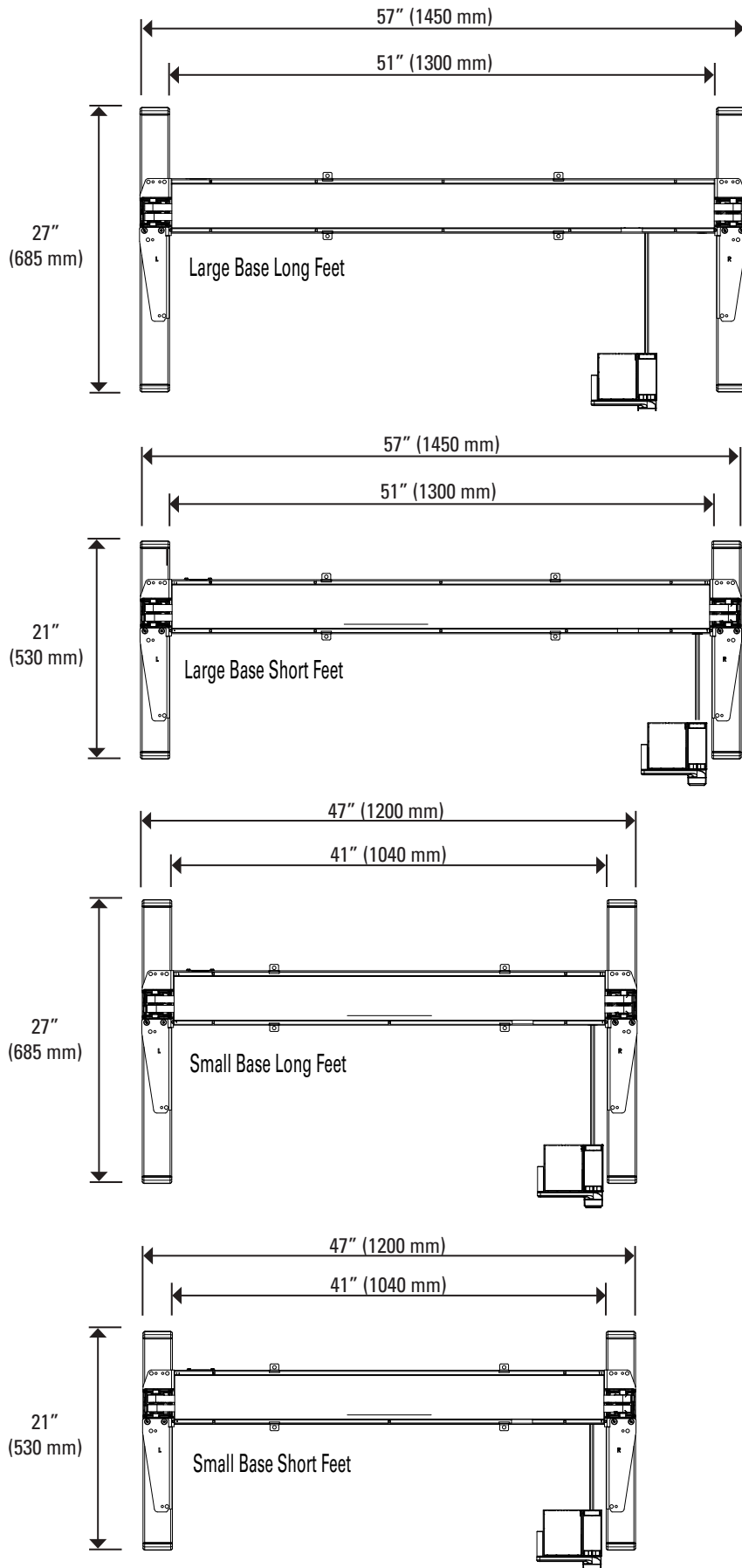

## Specifications

- Provides an exceptional 20" of height adjustability (27" to 47" from the floor, excluding tabletop thickness)
- Counterbalances up to 130 lbs. of desktop weight (including the tabletop)
- Accommodates work surface widths from 48" (1200 mm) to 72" (1800 mm) and depths from 24" (600 mm) to 30" (800 mm), including work surfaces from most manufacturers
- Meets BIFMA requirements for load, capacity and stability
- Made from recyclable steel and aluminum
- Includes a 5-year, 24/7 warranty

## Colors and Finishes

